



Ravaglioli

COMPANY WITH
QUALITY SYSTEM
CERTIFIED BY DNV GL
= ISO 9001 =

LIFTS



FLEXLOAD 10



EXPRESS SERVICE



ALIGNMENT LIFT



MAXLOAD 18



COLUMNS



SINCE 1958



2 POST LIFT

The "Flexload 10" is the most innovative design in the two post lift market since the innovation of the asymmetric lift.

The unique carriage design allows for the stronger straight column to be utilized without using a 90 degree front arm reducing stress. The result, a longer lasting lift that Will give you years of service without arm distortion common on so many US/China hybrid lifts.

FLEXIBILITY



Adjustable height.



Self-locking conical design

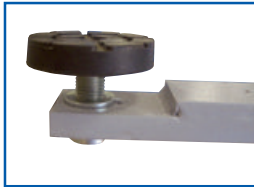

Very low pad, adjustable height

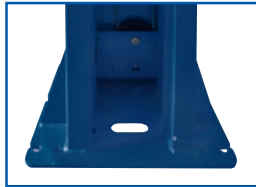

Pulley protected inside the column

QUALITY STANDARD FEATURES

- Last stage of all arms are solid steel (no tubing) allowing the pad to be lower than then arm. This allows easier access on low clearance cars with troublesome pickup points without damaging the rocker panel.
- Pulling cylinders, although more expensive to produce, reduce stress on the seals creating longer life.
- Quality single point lock system with non-friction cables that run over pulleys for longevity.
- Fully galvanized equalizing cables that will not rust from the inside out like US/China hybrids for more security.
- Non-slip rubber lifting pads with spin up adapters won't damage vehicle pickup points.
- Available in standard 142/146" model or Ultra Height 160/164" models ... at no additional cost.
- 3 phase models available at no additional cost (special order).
- Absolutely no Chinese components.

EXTRA RESISTANT COLUMN DESIGN

Exclusive 10+8 bending design to ensure max resistance to load.

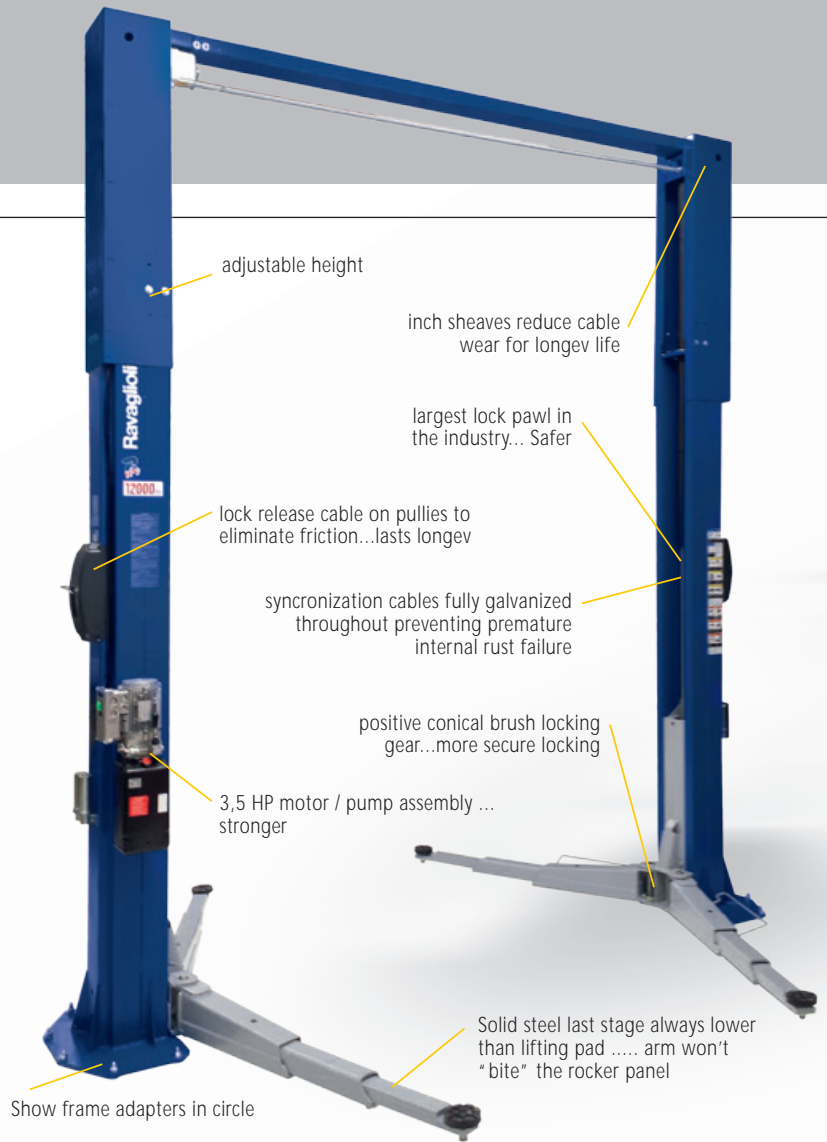
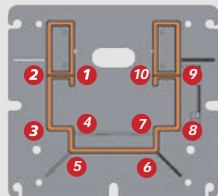
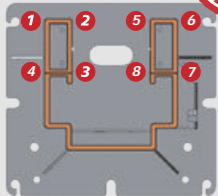
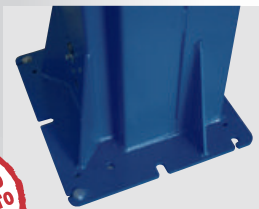

The "Flexload 10" is the only lift on the market with double wall column construction. Each column is constructed with 20 strength increasing bends making it the strongest column on the market.

OPTIONS

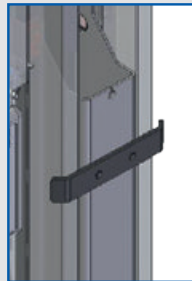

S370A5 (2 x kit)
Set of door protections



S5.337A2
Frame adapte



S224A4 (H=5 1/2")



4x Spacers

S370A18 (H=8")



4x



FLEXLOAD



10,000 lbs



STANDARD

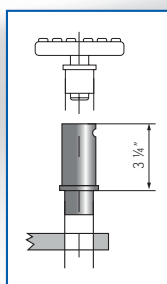

S224A3



S370A3 (2 x kit)
Spacer supports



KPH370.42YKU



10,000 lbs

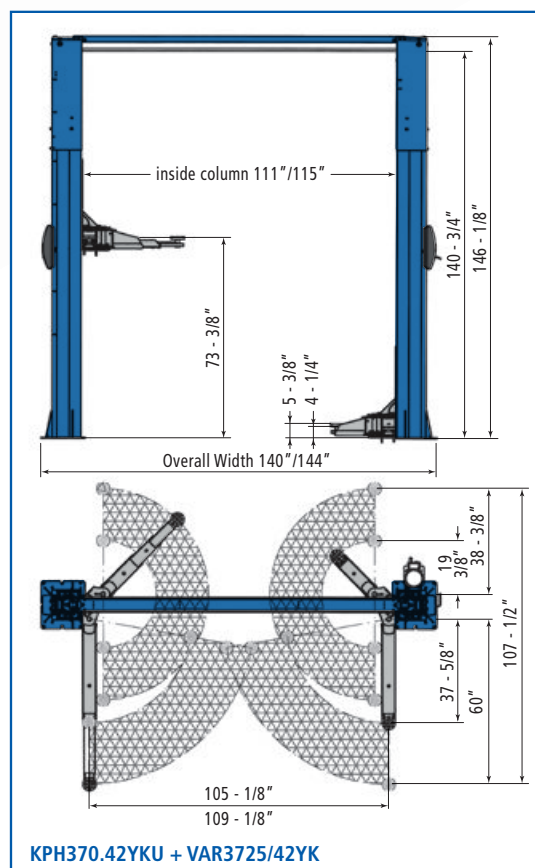
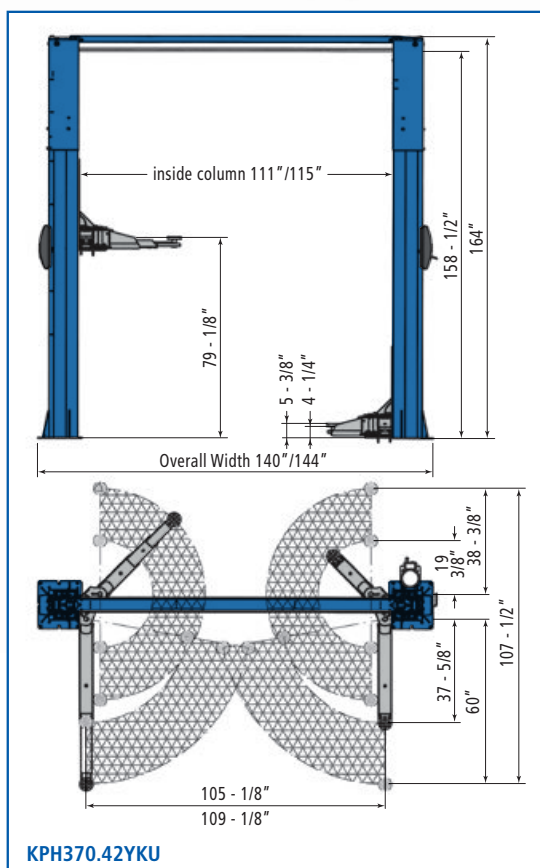



MAXLOAD 12-15



12,000 lbs

KPH370.50LIKU

12,000 lbs

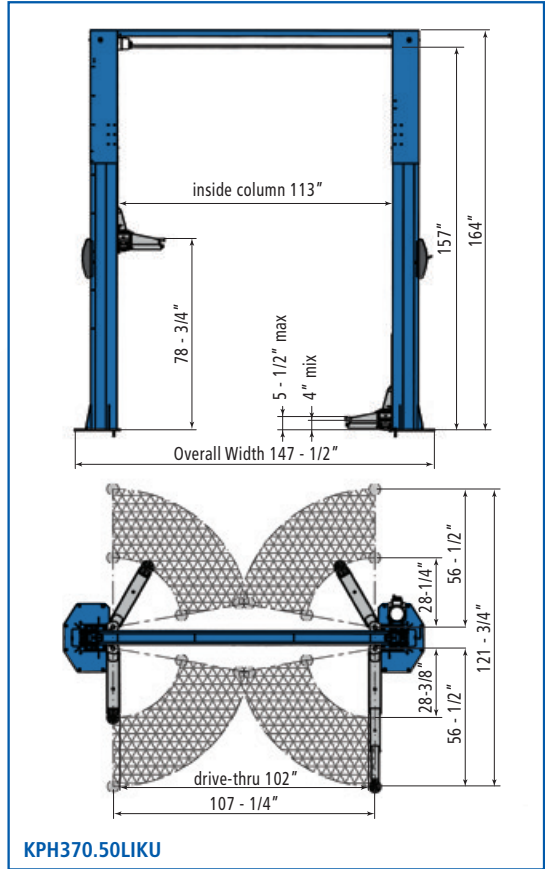

15,000 lbs

KPH370.55LIKU

15,000 lbs

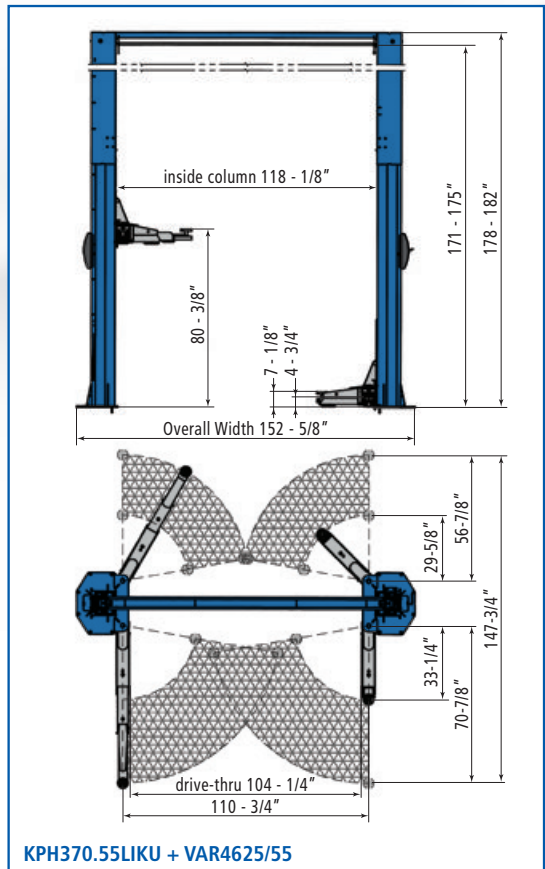



MAXLOAD 18

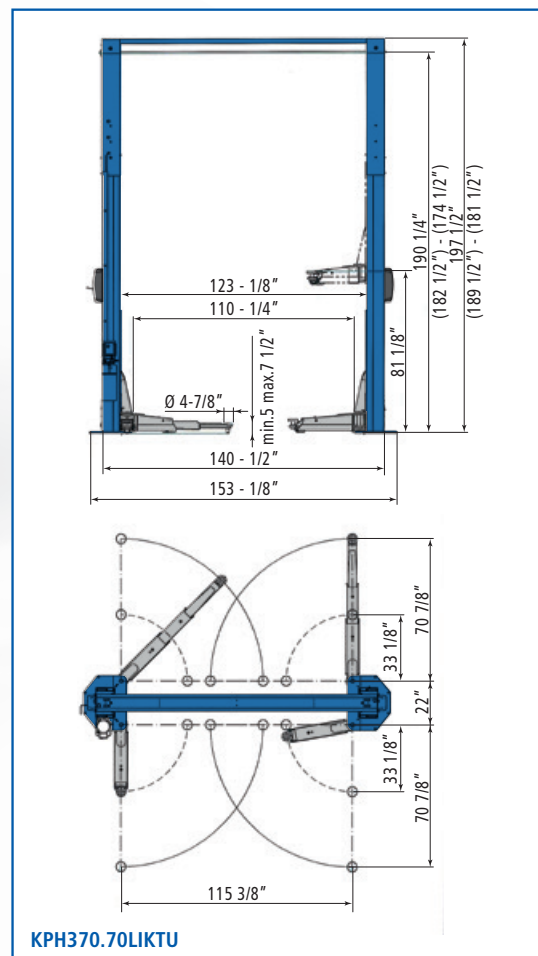

STANDARD

S370A7
(H=3 1/4")



S370A8
(H=5 1/2")
+ S5.337A2
Special support



OPTIONS

KPH370.55LIKT
KPH370.70LIKT

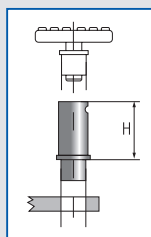

S224A3



S370A7
(H=3 1/4")

S224A4



S370A8
(H=5 1/2")

S370A18

S370A15
(H=8")



For Fiat Ducato, Peugeot
Boxer, Citroën Jumper
Spacers

S370A19

S370A16

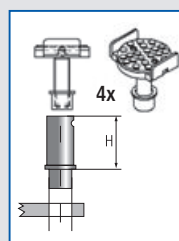

Frame adapters

S370A17

S370A14

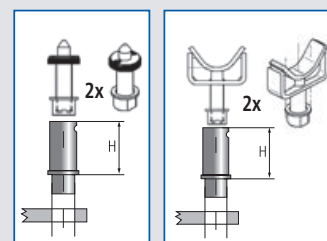

For Mercedes Sprinter, VW LT+Crafter
Adapters



IN-GROUND HIGH PRESSURE

RAV 1110NKU



10,000 lbs

Screw type pads can be adjusted as well as used with drop in extensions.

- Perfect synchronization between cylinders regardless of load distribution.
- Mechanical locking device with automatic engagement and pneumatic release, ensuring maximum safety when lift is raised.
- Dual purpose hydraulic safety valve prevents overloading and unexpected lowering should hose failure occur.
- Controlled lowering speed.
- All mechanical, hydraulic and electrical components manufactured in compliance with ALI/ETL.

10,000 lbs



RAV 1110NKU

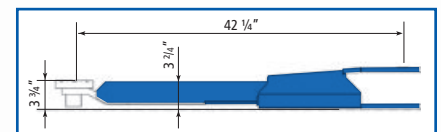
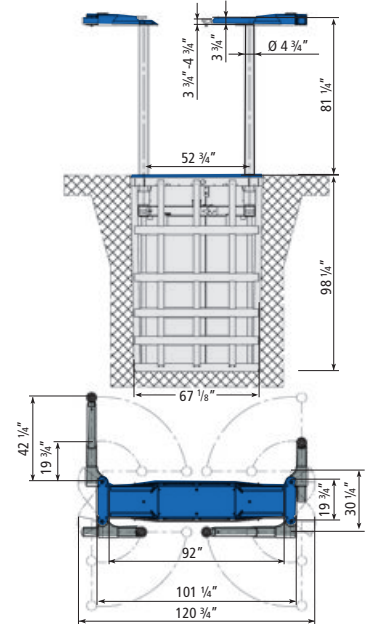

Extra low profile arms, parallel to the floor.



Pads can be adjusted in height and are suitable for quick housing of extensions.



Vehicle access completely free.



IN-GROUND HIGH PRESSURE



RAV 1120MU



10,000 lbs

Adjustable distance between the platform for different set-up pinch weld or frame vehicles.

The approach ramps can easily and quickly be locked in the horizontal position to serve as platform extensions.

Min. height: 3 7/8"



ADJUSTABLE PLATFORMS



Waterproof in-ground frame: steel frame and plastic cover.

Waterproof in-ground frame

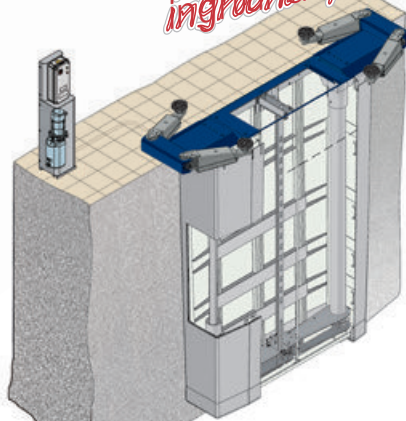

MAINTENANCE FREE CYLINDERS

Each column features a maintenance-free lifting cylinder.

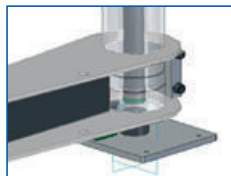

MAINTENANCE FREE GUIDES

Columns guides in oil bath, maintenance free.

HARD CHROME COLUMNS

Hard chromed guide tubes will not rust

SAFE: MECHANICAL LOCK

Mechanical safety latch with automatic engagements ensuring maximum safety when lift is in standing position.

DOUBLE JOINT

Cross bar with double joint to eliminate vibrations

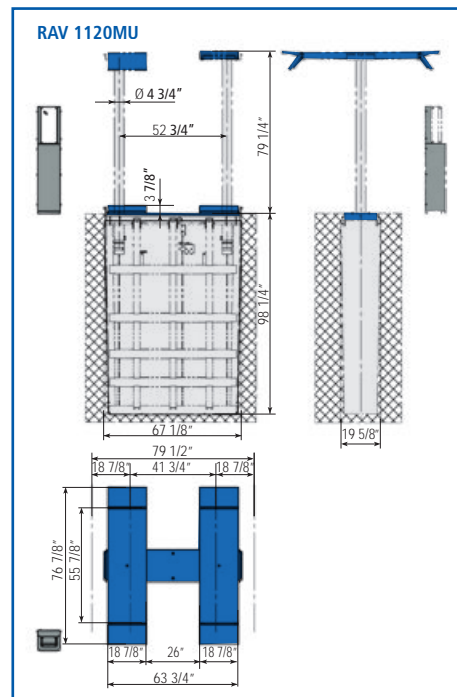
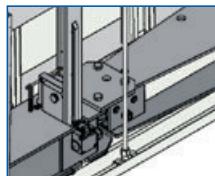



EXPRESS SERVICE

RAV 535U



7,000 lbs
Minimum height 3,9"

Extra low version.
The lift is an ideal choice for low ground clearance vehicles and in particular for extra low spoilers. The lift is recommended for vehicles with variable height, or damaged suspensions.

7,000 lbs

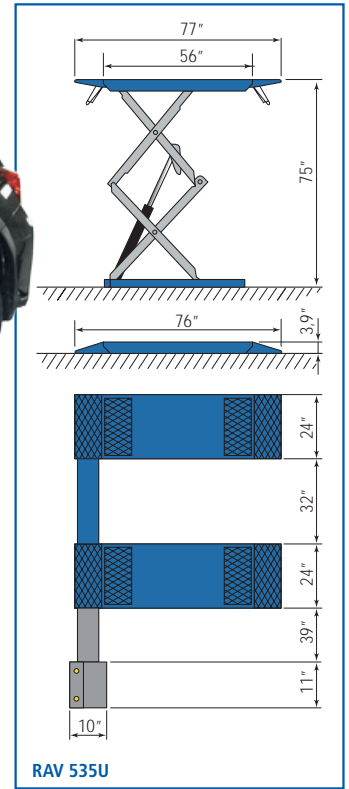

Shown w optional underfloor hoses

SELF LUBRICATING

All pivot points made with self lubricating bushings for long life.

MECHANICAL LOCK

Mechanical locking device with automatic engagement and pneumatic release, ensuring maximum safety when lift is in standing position.

- No cross rails or torsion bars between lifting platforms (for maximum accessibility in the working area).
- Controlled speed during initial lifting and final lowering phase.



Shown w optional underfloor hoses



EXPRESS SERVICE

RAV 540U



9,000 lbs
Minimum height 5,3"

High capacity model
with longer lifting
plates.

9,000 lbs

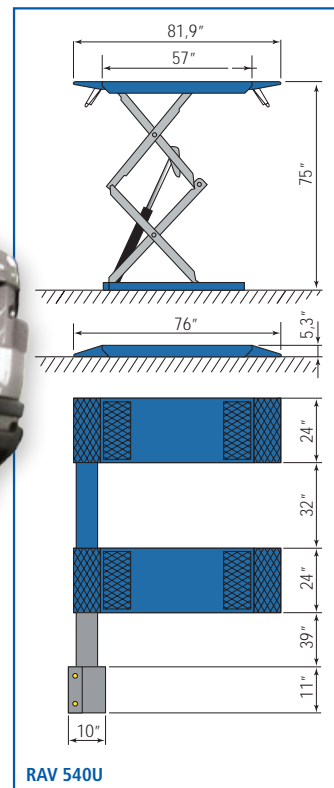

OPTIONS

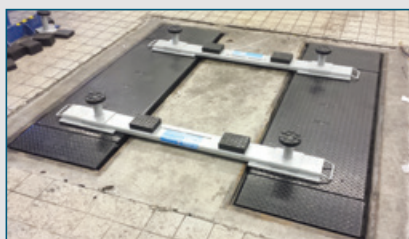

S 505 A2 (2 x kit)

Cross members

To provide safe wheel free lifting of vehicles
with narrow lifting points.



S 540A1

Kit with additional run up ramps for low ground
clearances vehicles

Set of pads (4 x kit)

S 505A1 H= 8"

S 505A5 H= 4 3/4"

S 505A6 H= 1 1/2"

S 505A7 H= 3/4"





ALIGNMENT LIFT

10,000 lbs
Scissor



RAV640.2

10,000 lbs

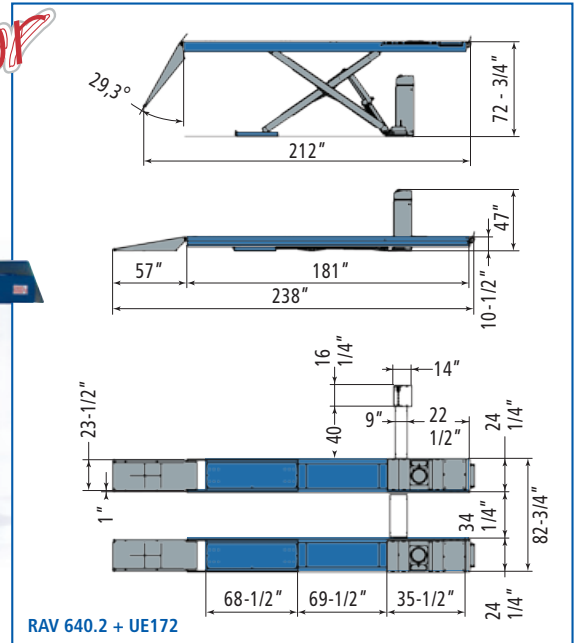

OPTIONAL PIT INSTALLATION SHOWN IN THE PICTURE

RECESSED VERSIONS

All can be supplied for recessed installation.



Hydraulic levelling system by means of a patented synchronisation device assures constantly level lifting platforms regardless of weight distribution.



Mechanical locking device with automatic engagement and pneumatic release, ensuring maximum safety when lift is rised.

ALIGNMENT LIFT

14,000 Scissor alignment lift

Top product
Made in Italy



RAV 660.2.55U



14,000 lbs

The best solution for a rational workshop:

- space saving when lift is raised
- obstacle free floor space when lift is fully lowered.

No cross rails or torsion bars between lifting platforms provides maximum accessibility in the working area.

Hydraulic levelling system by means of a patented synchronisation device assures constantly level lifting platforms regardless of weight distribution.

All pivot points made with self lubricating bushings for long life.

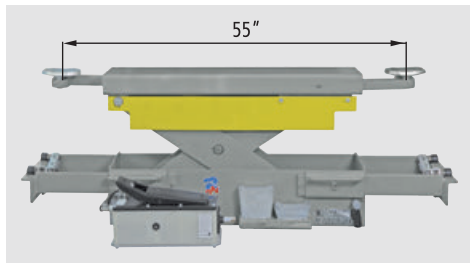
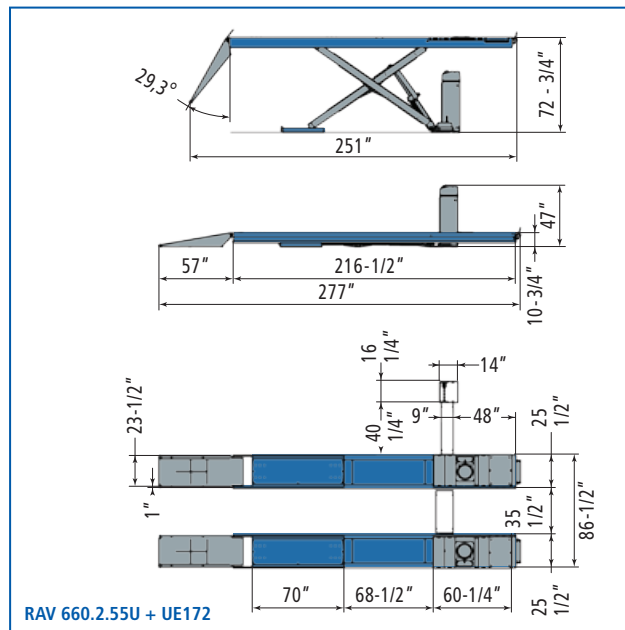
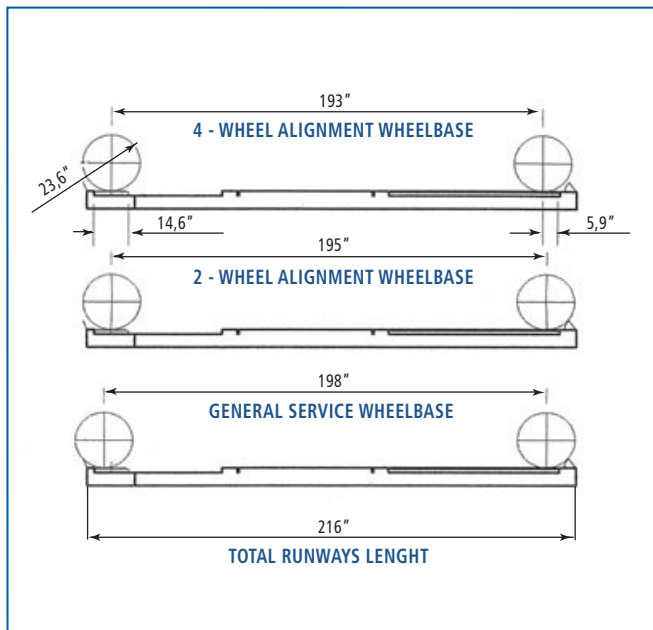

J30 PRU

7000 lbs

Heavy duty air-hydraulic rolling jacks. Scissors type.



RAV 660.5.55

14,000 lbs

Version with front hydraulic play detector.





ALIGNMENT LIFT

14,000 lbs premium alignment lift

RAV 4506 OFU



14,000 lbs

Extra-long platforms for total wheel alignment with front turning plates locations and rear slip plates.

Everything flush mounted for smooth access and perfect alignment work.



MULTI - POSITION



Multiposition turnplate cutouts with integral slide lock rear slip plates

OPEN FRONT

Full access to the working area

Low-friction rear slip plates.

They can be manually locked in central position. Transverse and angular movements in both directions.

RAV 4504 OFU



14,000 lbs

Lift with flat runways, with front recess for turntables and rear sliding plates mounted over the platform.

Low-friction rear slip plates. They can be manually locked in the central position. Transverse and angular movements in both directions.

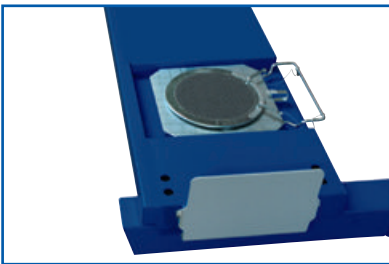

Alignment runways in front pocket pinned rear slip plates mounted over the platform

RAV 4503 OFU



14,000 lbs

Flat runways. The 224" long platforms and the large inner distance between posts allow optimum lifting of light commercial vehicles and long-wheelbase vans.

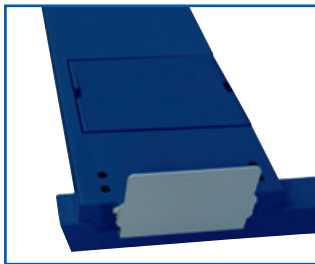

Flat runways with front pocket

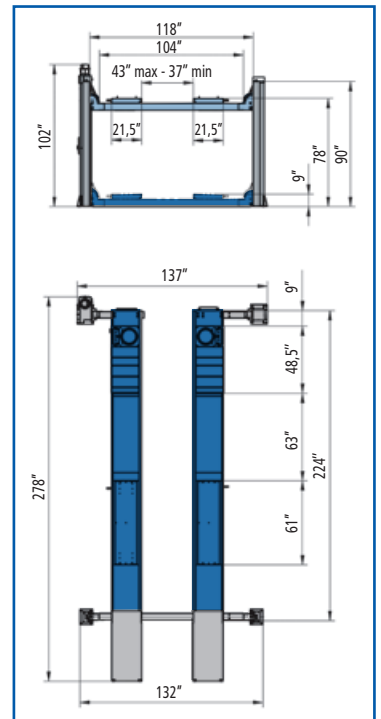

OPTIONS

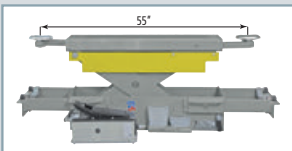

Heavy duty air-hydraulic rolling jacks. Scissors type.

J30

7000 lbs each

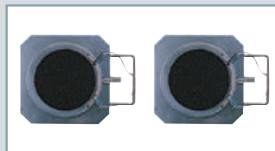

S110A7
12.2" diameter. Pair of heavy duty turntables.

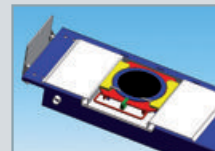

S4504 OF A1
(for RAV 4504 OF)
Kit to level S110A7 turntables for rolling run out compensation.



ELECTROMECHANICAL

RAV 212

7,000 lbs each column

RAV 222

9,000 lbs each column

RAV 232

12,000 lbs each column

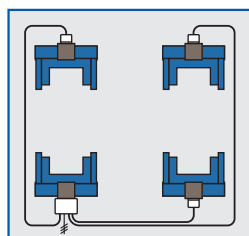

210-220-230-240 series
Handle (1 per set)

RAV212N, RAV222N, RAV232N:
controls only on master column
and operated as a set of 4 only.

RAV212NL, RAV222NL, RAV232NL:
system can be operated from any
post and individually as needed.



Master column control
NL series



Slave column control
NL series

RAV 242

16,000 lbs each column

RAV 262

19,000 lbs each column

RAV 272

22,500 lbs each column

Can be operated
from any post.



RAV 262

MODULAR

1 set of 8

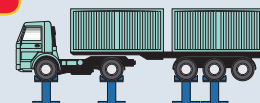

can become

2 sets of 4



AXLE HEIGHT SELECTION

Possibility of setting
a different heights
between pairs of
columns, retaining
the subsequent level
synchronization.

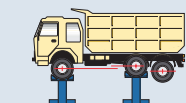

260-270 series
Hydraulic towing jack





HYDRAULIC

RAV 295H.4

12,000 lbs each column

Simultaneous operation of all columns.
Electronic system ensuring synchronization of all columns.
Safety stop in case of malfunction.
Low voltage controls (24 V) on the main column.

12,000 lbs



SPECIAL VERSION (→ VAR 290/F)



Version on demand featuring adjustable forks for wheels from 500 to 1200 mm in diameter.



RAV 295H
Handle (1 per set)

OPTIONS

WHEEL FREE CROSS-BEAM



S260A5 → max 15.000 kg
S270A7 → max 20.000 kg



S260A10
15,000 lbs frame kit (2 each set)



STANDS



S260A1 / 7500 kg
1330 - 2030 mm



S270A1 / 10000 kg
1235 - 2040 mm



S270A2 / 10000 kg
1235 - 2040 mm

S270A2
Spring-return wheels.



BATTERY

RAV 307H.4WS

16,000 lbs each column

RAV 305H.4WS

12,000 lbs each column

Control panel available on each column.
All columns identical.
Configuration sets: 4-6-8 columns.
Mechanical locking system/parking.
Wireless 2.4 GHz communication among columns.



DISPLAY INFORMATION

- Operation modes (all, group, single)
- Height of columns
- Battery charge condition
- Diagnostic / maintenance
- Number of column in a set

BATTERY CHARGER

One battery charger in each column.
10 meter charging cable.
Battery charger works as such, it is not for power supply.
Batteries can be charged during operation.
Recharging time approx. 10 hours.

OPERATION MODES

ALL: Simultaneous operation of all columns.

GROUP: Simultaneous operation of selected pairs of columns.

SINGLE: Single column operation.

SYNCHRONIZATION

Synchronization at a height difference of 30 mm.
Control board according to ISO standards 13849.

DATA TRANSMISSION CABLE

BATTERIES

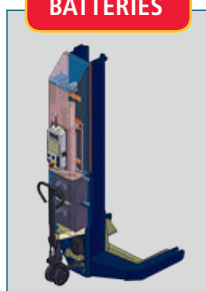

2 batteries in each column, 12V 100 A/h, gel type, maintenance-free.
20 lifting cycles with full load.

Battery charge leds:

- yellow led: battery charging recommended, 5 cycles still possible.
- red led: battery charging is required, 1 lowering cycle still possible.

260-270 series
Hydraulic towing jack



CONFIGURATIONS

4

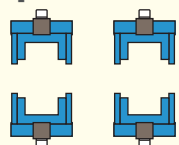

RAV 307H.4WS

6

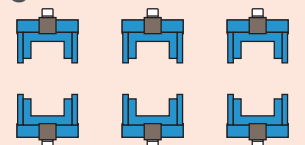

RAV 307H.6WS

8

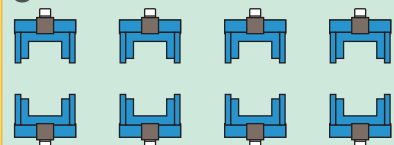

RAV 307H.8WS

OPTIONS

SPECIAL VERSION (→ VAR 300/F)



VAR307H/WS/LS (→ RAV 307HWS)
VAR308H/WS/LS (→ RAV 308HWS)

Two lowering speed: standard and slow.



Top product
Made in Italy



58 Years
of Excellence!



RAV Equipment U.S.A.
+1.703.887.0095
rav@ravaglioli.com

INTERNATIONAL
Ravaglioli S.p.A.
40037 Sasso Marconi
Fraz. Pontecchio M.
P.O.B. 1690 - Bologna - Italia
Tel. +39 - 051 - 6781511
Fax +39 - 051 - 846349
rav@ravaglioli.com
www.ravaglioli.com



RAV Equipment U.S.A.

Distributed by

AETechnologies, Inc
1082 Schoolhouse Rd
Harveys Lake, Pa, 18618
570 639 2344
1 877 RING AET

Edition 002

Technical data and composition presented in this catalogue may vary. Pictures reproduced are only indicative.